

CAD FILE :

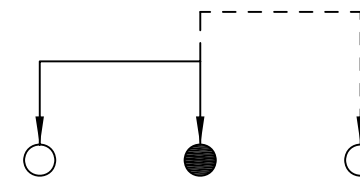

SCHEMATIC (NON-SHORTING)

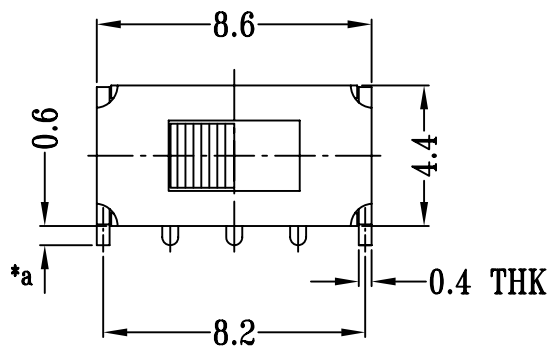
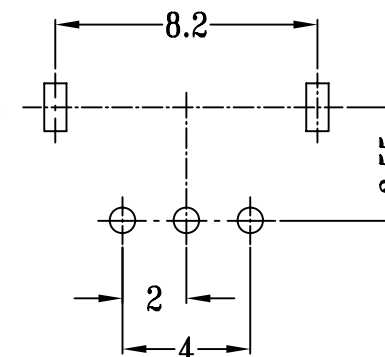
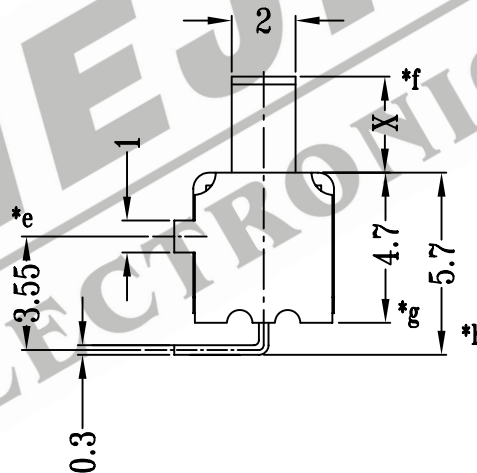
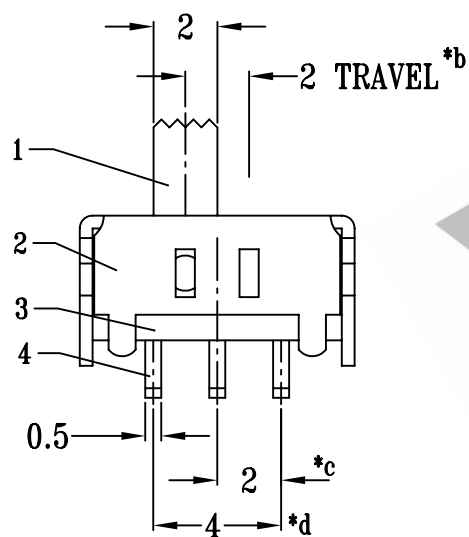

P.C.B LAYOUT

注:带"*"表示关键尺寸(8个)

NO.	PARTS	MATERIALS	Q'TY	FINISH	TOLERANCE UNLESS SPECIFIED	SHENZHEN XIEJIA ELECTRONICS CO.,LTD.				
8										
7										
6	SPRING PLATE	STAINLESS STEEL	1	NATURAL	WITHIN: 1.5±0.1mm OVER : 1.5±0.2mm	ISSUE	DATE	DESCRIPTIONS OF REVISION		APPD
5	CONTACT CLIP	PBS	1	Ag CLAD						
4	TERMINAL	BRASS STRIP	3	Ag PLATED OVER Ni PLATED	TITLE: VERTICAL SLIDE SWITCH	UNIT : mm		DRWG NO :XJ-DR-SS12D33-00		
3	BASE	PHENOLIC RESIN	1	NATURAL	MODEL: SS-12D33	SCALE : 4:1		DWN.	ZHOUYU	2002-8-15
2	FRAME	STEEL STRIP	1	Ni PLATED				CHK'D	FANGYING	2002-8-15
1	KNOB	POM	1	BLACK				APPD.	KANGXINAN	2002-8-15
					ALL MATERIALS MUST BE COMPLIANT TO ROHS					